

Customer : _____

No. _____

Date : _____

Attention : _____

Your ref. No. : _____

Your Part No. : _____

SPECIFICATIONS

PURPOSE OF THIS DOCUMENT;

- PRELIMINARY copy.
- Request for your APPROVAL.
(New, Engineering Change)
Please sign and return one copy.

APPROVED BY, Date: _____

X

Name

Title

- For PRODUCTION.

ALPS' ;

RK271122002LA

MODEL: (50k Bx2)

Spec. No. : 4K272A-63

Fig.No.: K272A0A0G

REMARKS:

MARKING

ON ALL UNITS

DATE CODE
RESIST, VALUE
TAPER
TRADE MARK
JAPAN

FURNISH PACKAGE

NUT		
WASHER		



ALPS ELECTRIC CO., LTD.

HEAD OFFICE

1-7, YUKIGAYA-OHTSUKA-CHO,
OHTA-KU, TOKYO 145 JAPAN

DSG'D

S. Sugawara

APP'D

Y. Kanyaki

ENG. DEPT. WAKUYA DIVISION

SHAFT SLOT IS OPTIONAL ANGLE

スリ割角度は任意とする。

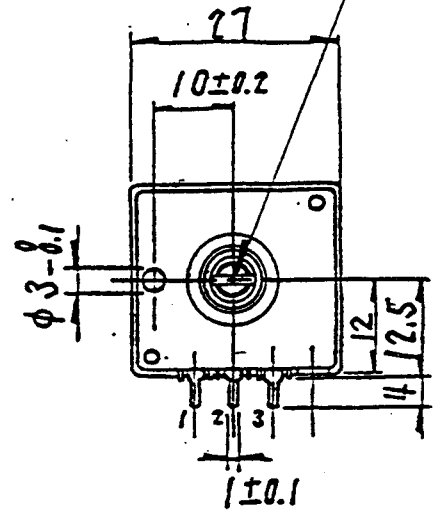
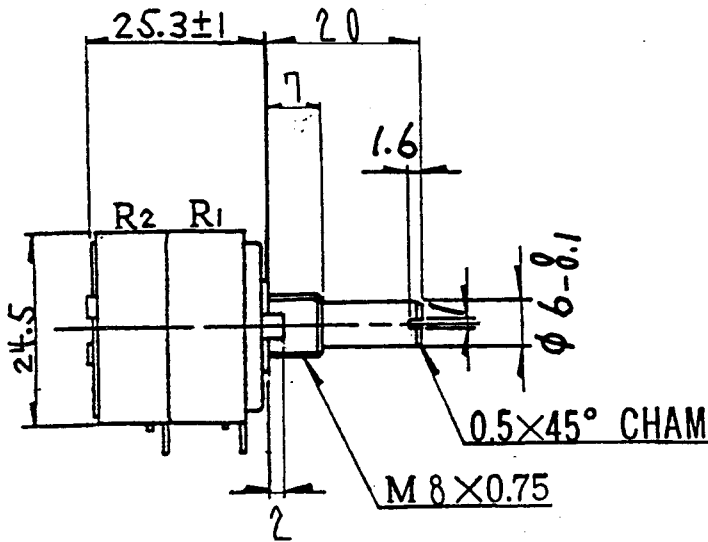

P.W.B. MOUNTING DETAIL
TOLERANCE ±0.1
VIEWED FROM MOUNTING SIDE

取付穴寸法図
許容差 ±0.1 (挿入側より)

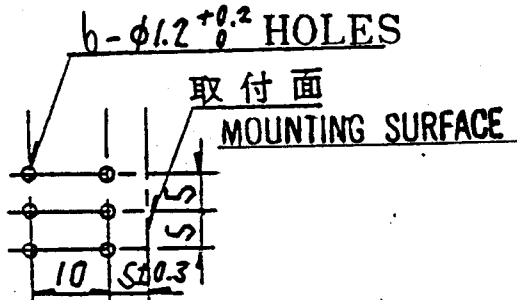

許容差の指定なき寸法の公差	
TOLERANCES UNLESS OTHERWISE SPEC	
BASIC DIMENSIONS	TOLERANCE
$L \leq 10$	±0.3
$10 < L < 100$	±0.5
$100 \leq L$	±0.8
角度 ANGULAR DIMENSION	±5°

部	番	名	称	材	料	規	格	処	理	300±3° 23.2g
..	三角法	単位 mm	尺度	150°	CLICK			
..	承認	照査	設計	図名				
..	57.9.7	57.9.-6	57.9.08	1軸2連小型ダイテントVR組立図				
..	大谷	佐々木	大和	図番 K272A0A0G 59.1.20				

Caution for soldering

Please avoid soldering on upper surface of P.C.B. as shown.

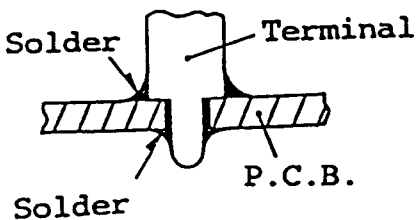

					ALPS ELECTRIC CO., LTD.			
	..				APPD.	CHKD.	DSGD.	TITLE
	..				設3課 89.8.-1 大谷	W設3 89.8.-1 浅田	設3 89.8.-1 阿部	DOCUMENT NO. (/)
SYMB.	DATE	APPD.	CHKD.	DSGD.				